

CJA28L05 Three-terminal positive voltage regulator

FEATURES

- Maximum output current
 I_o : 100mA
- Output voltage
 V_o : 5 V
- Continuous total dissipation
 P_D : Internal limited

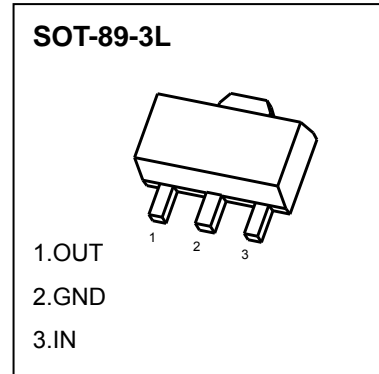

ABSOLUTE MAXIMUM RATINGS (Operating temperature range applies unless otherwise specified)

Parameter	Symbol	Value	Unit
Input Voltage Range	V_I	-0.3~+45	V
Operating Ambient Temperature Range	T_{OPR}	-40~+85	°C
Storage Temperature Range	T_{STG}	-55~+150	°C

ELECTRICAL CHARACTERISTICS ($V_I=12V, C_i=C_o=10\mu F$, unless otherwise specified)

Parameter	Symbol	Test conditions	Min	Typ	Max	Unit
Input voltage	V_I	$I_o=10mA$	4.75		40	V
Output voltage	V_o	$I_o=10mA$	4.9	5	5.1	V
Load regulation	ΔV_o	$I_o=1mA-100mA$		0.6		%
Line regulation	ΔV_o	$7V \leq V_I \leq 24V, V_o=5V, I_o=1mA$		0.02		%/V
		$7V \leq V_I \leq 45V, V_o=5V, I_o=1mA$		0.1		%/V
Quiescent current	I_q	$V_I=7V, \text{No load}$			15	μA
		$V_I=24V, \text{No load}$			16	
		$V_I=40V, \text{No load}$			20	
Dropout Voltage	V_d	$I_o=1mA$			12	mV
		$I_o=100mA$			1200	mV
Output noise voltage	V_N	$I_o=10mA$	-100		100	μV
Ripple rejection	RR	$V_I=7V, C_{J78L05}$ $V_{PP}=0.5V,$ $I_o=1mA$	$f=100Hz$		60	dB
			$f=1kHz$		45	
			$f=10kHz$		35	
Maximum output current	I_{PK}	$R_L=1\Omega$	180		460	mA
Thermal protection	TSD	$I_o=1mA$		165		°C
Thermal protection Hys	T_{SD_HYS}	$I_o=1mA$		30		°C
Temperature coefficient	$\Delta V_o/\Delta T$	$I_o=1mA$		± 0.5		mV/°C

TYPICAL APPLICATION

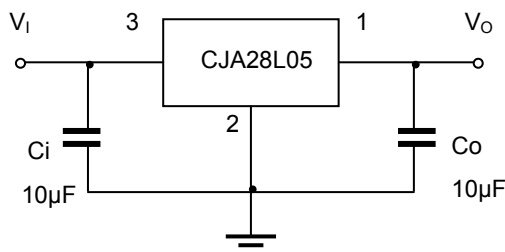

Typical Characteristics

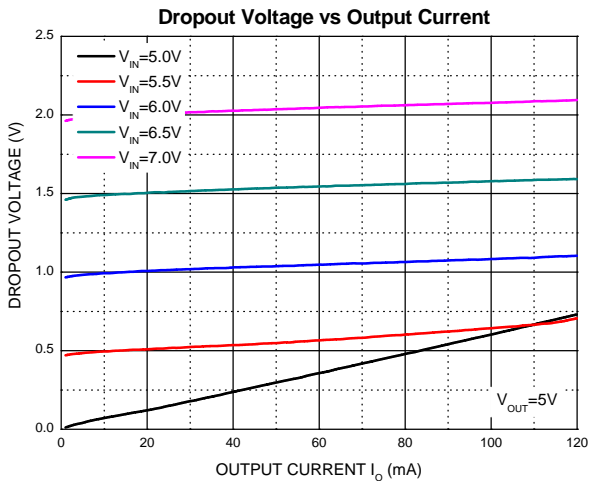
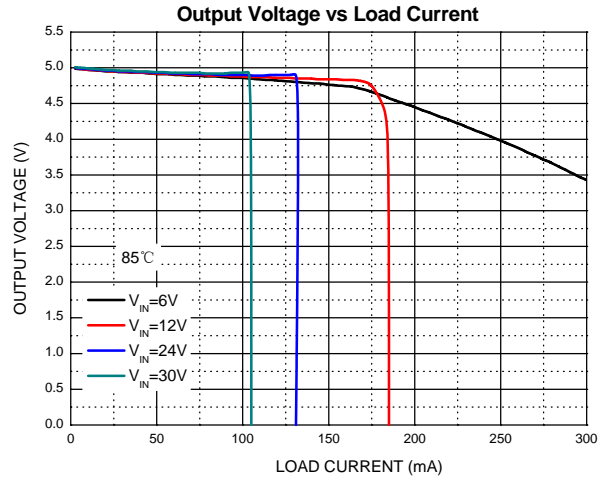
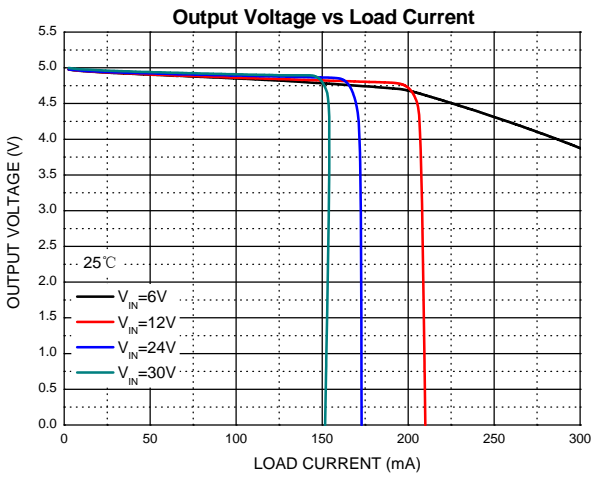
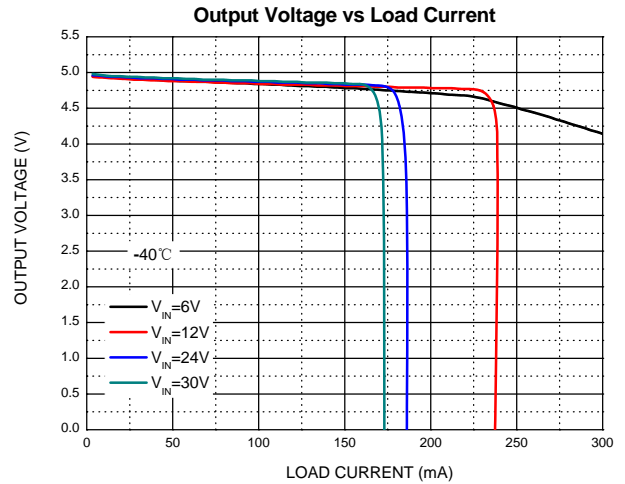
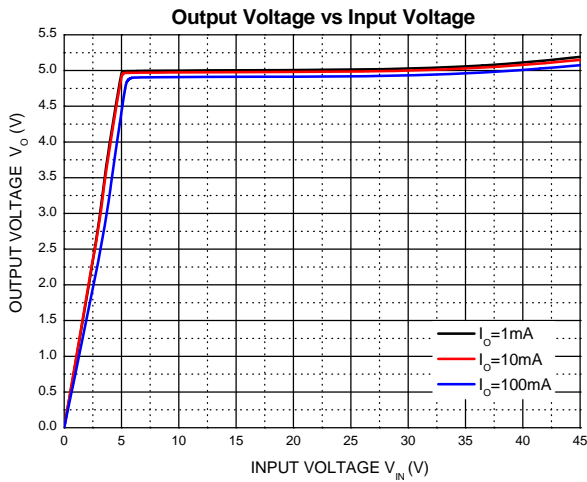
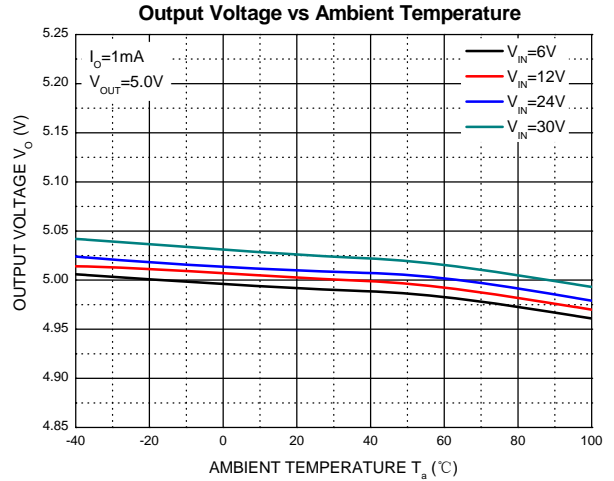
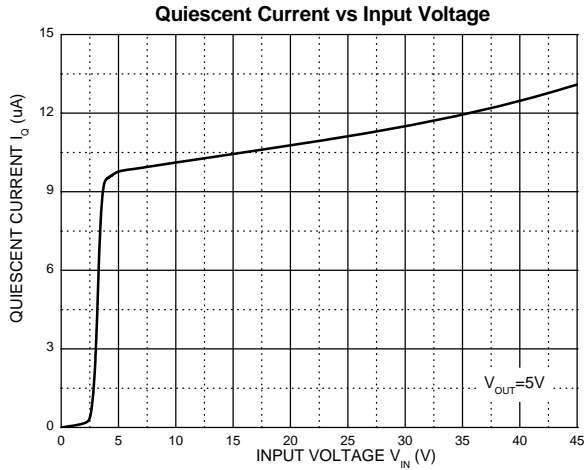

SOT-89-3L Package Outline Dimensions

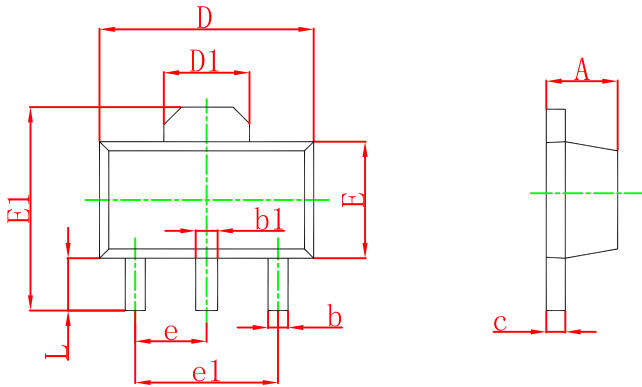

Symbol	Dimensions In Millimeters		Dimensions In Inches	
	Min	Max	Min	Max
A	1.400	1.600	0.055	0.063
b	0.320	0.520	0.013	0.020
b1	0.400	0.580	0.016	0.023
c	0.350	0.440	0.014	0.017
D	4.400	4.600	0.173	0.181
D1	1.550 REF.		0.061 REF.	
E	2.300	2.600	0.091	0.102
E1	3.940	4.250	0.155	0.167
e	1.500 TYP.		0.060 TYP.	
e1	3.000 TYP.		0.118 TYP.	
L	0.900	1.200	0.035	0.047

SOT-89-3L Suggested Pad Layout



Note:

1. Controlling dimension: in millimeters.
2. General tolerance: ± 0.05 mm.
3. The pad layout is for reference purposes only.

SOT-89-3L Tape and Reel

SOT-89-3L Embossed Carrier Tape



Packaging Description:

SOT-89-3L parts are shipped in tape. The carrier tape is made from a dissipative (carbon filled) polycarbonate resin. The cover tape is a multilayer film (Heat Activated Adhesive in nature) primarily composed of polyester film, adhesive layer, sealant, and anti-static sprayed agent. These reeled parts in standard option are shipped with 1,000 units per 7" or 18.0 cm diameter reel. The reels are clear in color and is made of polystyrene plastic (anti-static coated).

Dimensions are in millimeter										
Pkg type	A	B	C	d	E	F	P0	P	P1	W
SOT-89-3L	4.85	4.45	1.85	Ø1.50	1.75	5.50	4.00	8.00	2.00	12.00

SOT-89-3L Tape Leader and Trailer

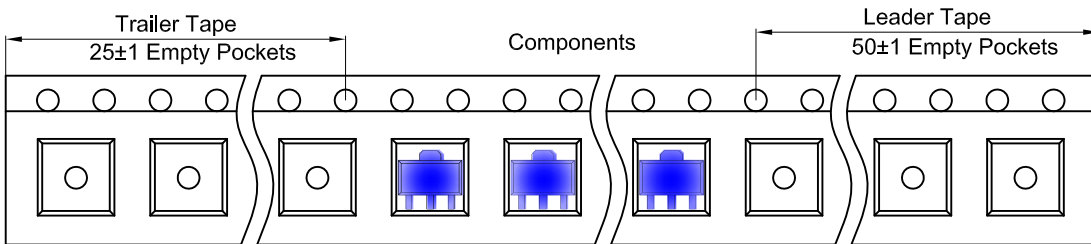

SOT-89-3L Reel

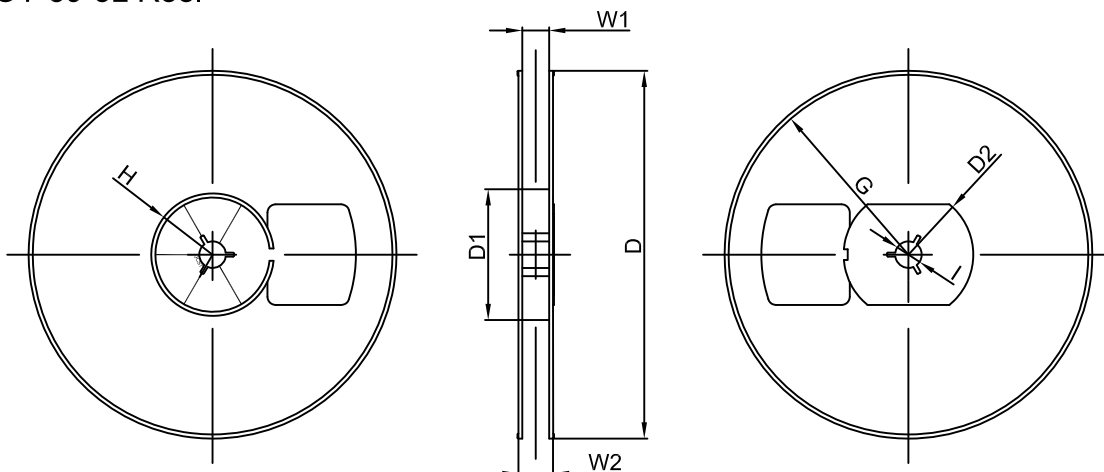

Dimensions are in millimeter								
Reel Option	D	D1	D2	G	H	I	W1	W2
7" Dia	Ø180.00	60.00	R32.00	R86.50	R30.00	Ø13.00	13.20	16.50

REEL	Reel Size	Box	Box Size(mm)	Carton	Carton Size(mm)	G.W.(kg)
1000 pcs	7 inch	10,000 pcs	203×203×195	40,000 pcs	438×438×220	